

### PIN DESCRIPTION

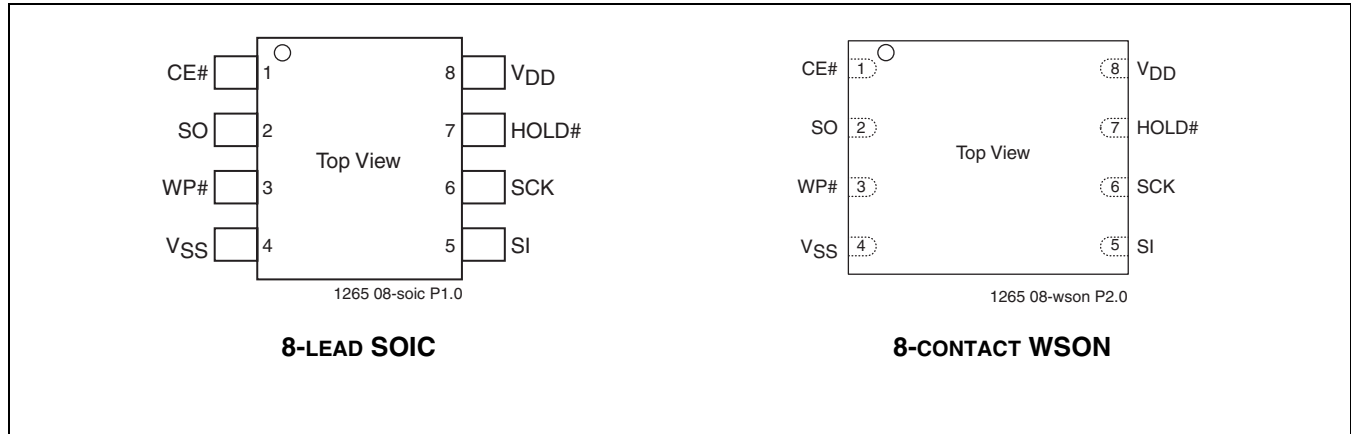

**FIGURE 1: PIN ASSIGNMENTS**

**TABLE 1: PIN DESCRIPTION**

Symbol	Pin Name	Functions
SCK	Serial Clock	To provide the timing of the serial interface. Commands, addresses, or input data are latched on the rising edge of the clock input, while output data is shifted out on the falling edge of the clock input.
SI	Serial Data Input	To transfer commands, addresses, or data serially into the device. Inputs are latched on the rising edge of the serial clock.
SO	Serial Data Output	To transfer data serially out of the device. Data is shifted out on the falling edge of the serial clock.
CE#	Chip Enable	The device is enabled by a high to low transition on CE#. CE# must remain low for the duration of any command sequence.
WP#	Write Protect	The Write Protect (WP#) pin is used to enable/disable BPL bit in the status register.
HOLD#	Hold	To temporarily stop serial communication with SPI flash memory without resetting the device.
V <sub>DD</sub>	Power Supply	To provide power supply (2.7-3.6V).
V <sub>SS</sub>	Ground	

T1.0 1265



**PRODUCT IDENTIFICATION**

**TABLE 2: PRODUCT IDENTIFICATION**

	Address	Data
Manufacturer's ID	00000H	BFH
Device ID PCT25VF010A	0001H	49H

T2.0 1265

**MEMORY ORGANIZATION**

The PCT25VF010A SuperFlash memory array is organized in 4 KByte sectors with 32 KByte overlay blocks.

**DEVICE OPERATION**

The PCT25VF010A is accessed through the SPI (Serial Peripheral Interface) bus compatible protocol. The SPI bus consist of four control lines; Chip Enable (CE#) is used to select the device, and data is accessed through the Serial Data Input (SI), Serial Data Output (SO), and Serial Clock (SCK).

The PCT25VF010A supports both Mode 0 (0,0) and Mode 3 (1,1) of SPI bus operations. The difference between the two modes, as shown in Figure 2, is the state of the SCK signal when the bus master is in Stand-by mode and no data is being transferred. The SCK signal is low for Mode 0 and SCK signal is high for Mode 3. For both modes, the Serial Data In (SI) is sampled at the rising edge of the SCK clock signal and the Serial Data Output (SO) is driven after the falling edge of the SCK clock signal.

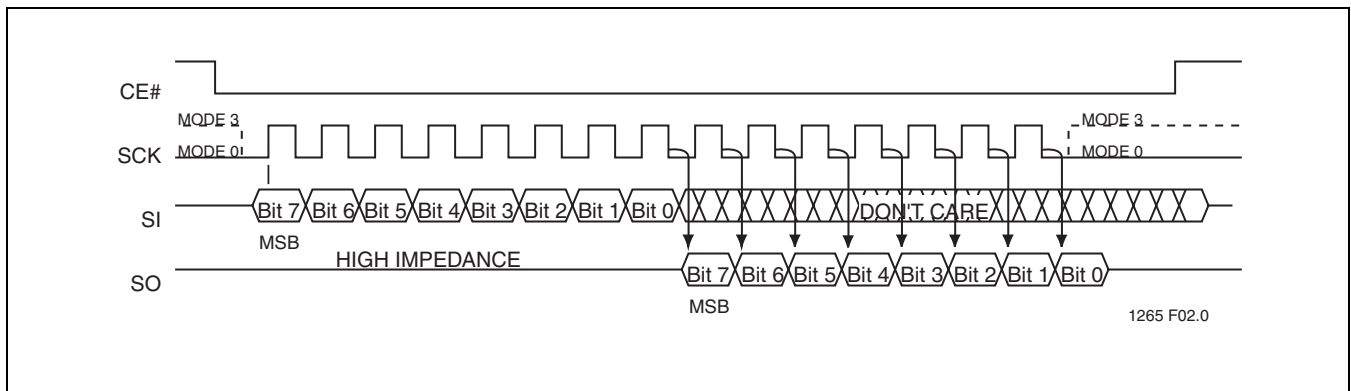

**FIGURE 2: SPI PROTOCOL**



# 1 Mbit SPI Serial Flash D7 H25VF010A

Data Sheet

## Hold Operation

HOLD# pin is used to pause a serial sequence underway with the SPI flash memory without resetting the clocking sequence. To activate the HOLD# mode, CE# must be in active low state. The HOLD# mode begins when the SCK active low state coincides with the falling edge of the HOLD# signal. The HOLD mode ends when the HOLD# signal's rising edge coincides with the SCK active low state.

If the falling edge of the HOLD# signal does not coincide with the SCK active low state, then the device enters Hold mode when the SCK next reaches the active low state. Similarly, if the rising edge of the HOLD# signal does not

coincide with the SCK active low state, then the device exits in Hold mode when the SCK next reaches the active low state. See Figure 3 for Hold Condition waveform.

Once the device enters Hold mode, SO will be in high-impedance state while SI and SCK can be  $V_{IL}$  or  $V_{IH}$ .

If CE# is driven active high during a Hold condition, it resets the internal logic of the device. As long as HOLD# signal is low, the memory remains in the Hold condition. To resume communication with the device, HOLD# must be driven active high, and CE# must be driven active low. See Figure 18 for Hold timing.

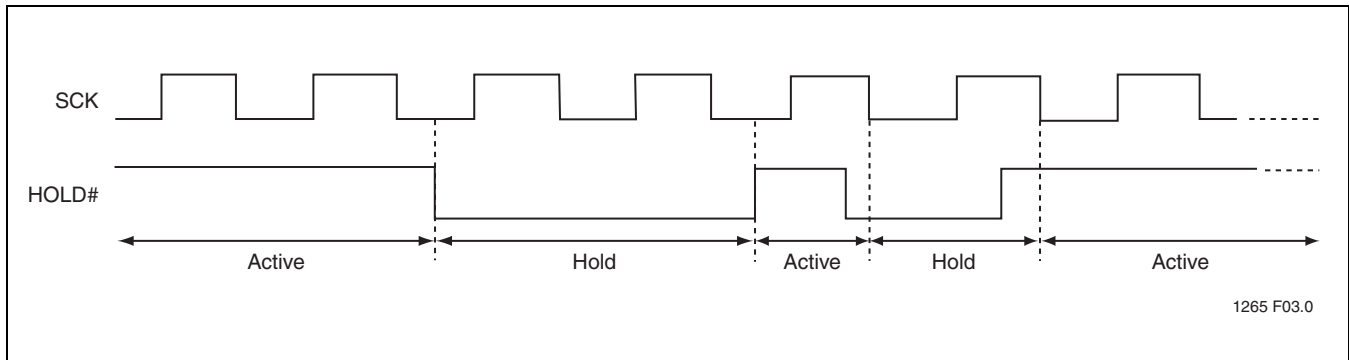

**FIGURE 3: HOLD CONDITION WAVEFORM**

## Write Protection

The PCT25VF010A provides software Write protection. The Write Protect pin (WP#) enables or disables the lock-down function of the status register. The Block-Protection bits (BP1, BP0, and BPL) in the status register provide Write protection to the memory array and the status register. See Table 5 for Block-Protection description.

### Write Protect Pin (WP#)

The Write Protect (WP#) pin enables the lock-down function of the BPL bit (bit 7) in the status register. When WP# is driven low, the execution of the Write-Status-Register (WRSR) instruction is determined by the value of the BPL bit (see Table 3). When WP# is high, the lock-down function of the BPL bit is disabled.

**TABLE 3: CONDITIONS TO EXECUTE WRITE-STATUS-REGISTER (WRSR) INSTRUCTION**

WP#	BPL	Execute WRSR Instruction
L	1	Not Allowed
L	0	Allowed
H	X	Allowed

T3.0 1265



## Status Register

The software status register provides status on whether the flash memory array is available for any Read or Write operation, whether the device is Write enabled, and the state of the memory Write protection. During an internal Erase or

Program operation, the status register may be read only to determine the completion of an operation in progress. Table 4 describes the function of each bit in the software status register.

**TABLE 4: SOFTWARE STATUS REGISTER**

Bit	Name	Function	Default at Power-up	Read/Write
0	BUSY	1 = Internal Write operation is in progress 0 = No internal Write operation is in progress	0	R
1	WEL	1 = Device is memory Write enabled 0 = Device is not memory Write enabled	0	R
2	BP0	Indicate current level of block write protection (See Table 5)	1	R/W
3	BP1	Indicate current level of block write protection (See Table 5)	1	R/W
4:5	RES	Reserved for future use	0	N/A
6	AAI	Auto Address Increment Programming status 1 = AAI programming mode 0 = Byte-Program mode	0	R
7	BPL	1 = BP1, BP0 are read-only bits 0 = BP1, BP0 are read/writable	0	R/W

T4.0 1265

### Busy

The Busy bit determines whether there is an internal Erase or Program operation in progress. A “1” for the Busy bit indicates the device is busy with an operation in progress. A “0” indicates the device is ready for the next valid operation.

### Write Enable Latch (WEL)

The Write-Enable-Latch bit indicates the status of the internal memory Write Enable Latch. If the Write-Enable-Latch bit is set to “1”, it indicates the device is Write enabled. If the bit is set to “0” (reset), it indicates the device is not Write enabled and does not accept any memory Write (Program/Erase) commands. The Write-Enable-Latch bit is automatically reset under the following conditions:

- Power-up
- Write-Disable (WRDI) instruction completion
- Byte-Program instruction completion
- Auto Address Increment (AAI) programming reached its highest memory address
- Sector-Erase instruction completion
- Block-Erase instruction completion
- Chip-Erase instruction completion



# 1 Mbit SPI Serial Flash D7 T25VF010A

## Block Protection (BP1, BP0)

The Block-Protection (BP1, BP0) bits define the size of the memory area, as defined in Table 5, to be software protected against any memory Write (Program or Erase) operations. The Write-Status-Register (WRSR) instruction is used to program the BP1 and BP0 bits as long as WP# is high or the Block-Protect-Lock (BPL) bit is 0. Chip-Erase can only be executed if Block-Protection bits are both 0. After power-up, BP1 and BP0 are set to 1.

## Block Protection Lock-Down (BPL)

WP# pin driven low ( $V_{IL}$ ), enables the Block-Protection-Lock-Down (BPL) bit. When BPL is set to 1, it prevents any further alteration of the BPL, BP1, and BP0 bits. When the WP# pin is driven high ( $V_{IH}$ ), the BPL bit has no effect and its value is "Don't Care". After power-up, the BPL bit is reset to 0.

**TABLE 5: SOFTWARE STATUS REGISTER  
BLOCK PROTECTION<sup>1</sup>**

Protection Level	Status Register Bit		Protected Memory Area
	BP1	BP0	
0	0	0	None
1 (1/4 Memory Array)	0	1	018000H-01FFFFH
2 (1/2 Memory Array)	1	0	010000H-01FFFFH
3 (Full Memory Array)	1	1	000000H-01FFFFH

T5.0 1265

1. Default at power-up for BP1 and BP0 is '11'.

## Auto Address Increment (AAI)

The Auto Address Increment Programming-Status bit provides status on whether the device is in AAI programming mode or Byte-Program mode. The default at power up is Byte-Program mode.



## Data Sheet

### Instructions

Instructions are used to Read, Write (Erase and Program), and configure the PCT25VF010A. The instruction bus cycles are 8 bits each for commands (Op Code), data, and addresses. Prior to executing any Byte-Program, Auto Address Increment (AAI) programming, Sector-Erase, Block-Erase, or Chip-Erase instructions, the Write-Enable (WREN) instruction must be executed first. The complete list of the instructions is provided in Table 6. All instructions are synchronized off a high to low transition of CE#. Inputs will be accepted on the rising edge of SCK starting with the

most significant bit. CE# must be driven low before an instruction is entered and must be driven high after the last bit of the instruction has been shifted in (except for Read, Read-ID and Read-Status-Register instructions). Any low to high transition on CE#, before receiving the last bit of an instruction bus cycle, will terminate the instruction in progress and return the device to the standby mode. Instruction commands (Op Code), addresses, and data are all input from the most significant bit (MSB) first.

**TABLE 6: DEVICE OPERATION INSTRUCTIONS<sup>1</sup>**

Bus Cycle <sup>2</sup>	1		2		3		4		5		6	
	S <sub>IN</sub>	S <sub>OUT</sub>	S <sub>IN</sub>	S <sub>OUT</sub>	S <sub>IN</sub>	S <sub>OUT</sub>	S <sub>IN</sub>	S <sub>OUT</sub>	S <sub>IN</sub>	S <sub>OUT</sub>	S <sub>IN</sub>	S <sub>OUT</sub>
Read (20 MHz)	03H	Hi-Z	A <sub>23</sub> -A <sub>16</sub>	Hi-Z	A <sub>15</sub> -A <sub>8</sub>	Hi-Z	A <sub>7</sub> -A <sub>0</sub>	Hi-Z	X	D <sub>OUT</sub>		
High-Speed-Read (33 MHz)	0BH	Hi-Z	A <sub>23</sub> -A <sub>16</sub>	Hi-Z	A <sub>15</sub> -A <sub>8</sub>	Hi-Z	A <sub>7</sub> -A <sub>0</sub>	Hi-Z	X	X	X	D <sub>OUT</sub>
Sector-Erase <sup>5,6</sup>	20H	Hi-Z	A <sub>23</sub> -A <sub>16</sub>	Hi-Z	A <sub>15</sub> -A <sub>8</sub>	Hi-Z	A <sub>7</sub> -A <sub>0</sub>	Hi-Z	-	-		
Block-Erase <sup>5,7</sup>	52H or D8H	Hi-Z	A <sub>23</sub> -A <sub>16</sub>	Hi-Z	A <sub>15</sub> -A <sub>8</sub>	Hi-Z	A <sub>7</sub> -A <sub>0</sub>	Hi-Z	-	-		
Chip-Erase <sup>6</sup>	60H or C7H	Hi-Z	-	-	-	-	-	-	-	-		
Byte-Program <sup>6</sup>	02H	Hi-Z	A <sub>23</sub> -A <sub>16</sub>	Hi-Z	A <sub>15</sub> -A <sub>8</sub>	Hi-Z	A <sub>7</sub> -A <sub>0</sub>	Hi-Z	D <sub>IN</sub>	Hi-Z		Hi-Z
Auto Address Increment (AAI) Program <sup>6,8</sup>	AFH	Hi-Z	A <sub>23</sub> -A <sub>16</sub>	Hi-Z	A <sub>15</sub> -A <sub>8</sub>	Hi-Z	A <sub>7</sub> -A <sub>0</sub>	Hi-Z	D <sub>IN</sub>	Hi-Z		Hi-Z
Read-Status-Register (RDSR)	05H	Hi-Z	X	D <sub>OUT</sub>	-	Note <sup>9</sup>	-	Note <sup>9</sup>	-	Note <sup>9</sup>		Note <sup>9</sup>
Enable-Write-Status-Register (EWSR) <sup>10</sup>	50H	Hi-Z	-	-	-	-	-	-	-	-		
Write-Status-Register (WRSR) <sup>10</sup>	01H	Hi-Z	Data	Hi-Z	-	-	-	-	-	-		
Write-Enable (WREN)	06H	Hi-Z	-	-	-	-	-	-	-	-		
Write-Disable (WRDI)	04H	Hi-Z	-	-	-	-	-	-	-	-		
Read-ID	90H or ABH	Hi-Z	00H	Hi-Z	00H	Hi-Z	ID Addr <sup>11</sup>	Hi-Z	X	D <sub>OUT</sub> <sup>12</sup>		D <sub>OUT</sub> <sup>12</sup>

T6.0 1265

1. A<sub>MS</sub> = Most Significant Address  
A<sub>MS</sub> = A<sub>16</sub> for PCT25VF010A  
Address bits above the most significant bit of each density can be V<sub>IL</sub> or V<sub>IH</sub>
2. One bus cycle is eight clock periods.
3. Operation: S<sub>IN</sub> = Serial In, S<sub>OUT</sub> = Serial Out
4. X = Dummy Input Cycles (V<sub>IL</sub> or V<sub>IH</sub>); - = Non-Applicable Cycles (Cycles are not necessary)
5. Sector addresses: use A<sub>MS</sub>-A<sub>12</sub>, remaining addresses can be V<sub>IL</sub> or V<sub>IH</sub>
6. Prior to any Byte-Program, AAI-Program, Sector-Erase, Block-Erase, or Chip-Erase operation, the Write-Enable (WREN) instruction must be executed.
7. Block addresses for: use A<sub>MS</sub>-A<sub>15</sub>, remaining addresses can be V<sub>IL</sub> or V<sub>IH</sub>
8. To continue programming to the next sequential address location, enter the 8-bit command, AFH, followed by the data to be programmed.
9. The Read-Status-Register is continuous with ongoing clock cycles until terminated by a low to high transition on CE#.
10. The Enable-Write-Status-Register (EWSR) instruction and the Write-Status-Register (WRSR) instruction must work in conjunction of each other. The WRSR instruction must be executed immediately (very next bus cycle) after the EWSR instruction to make both instructions effective.
11. Manufacturer's ID is read with A<sub>0</sub>=0, and Device ID is read with A<sub>0</sub>=1. All other address bits are 00H. The Manufacturer's and Device ID output stream is continuous until terminated by a low to high transition on CE#
12. Device ID = 49H for PCT25VF010A





# 1 Mbit SPI Serial Flash D7 T25VF010A

## Read (20 MHz)

The Read instruction outputs the data starting from the specified address location. The data output stream is continuous through all addresses until terminated by a low to high transition on CE#. The internal address pointer will automatically increment until the highest memory address is reached. Once the highest memory address is reached, the address pointer will automatically increment to the beginning (wrap-around) of the address space, i.e. for

4 Mbit density, once the data from address location 7FFFFH had been read, the next output will be from address location 00000H.

The Read instruction is initiated by executing an 8-bit command, 03H, followed by address bits [A<sub>23</sub>-A<sub>0</sub>]. CE# must remain active low for the duration of the Read cycle. See Figure 4 for the Read sequence.

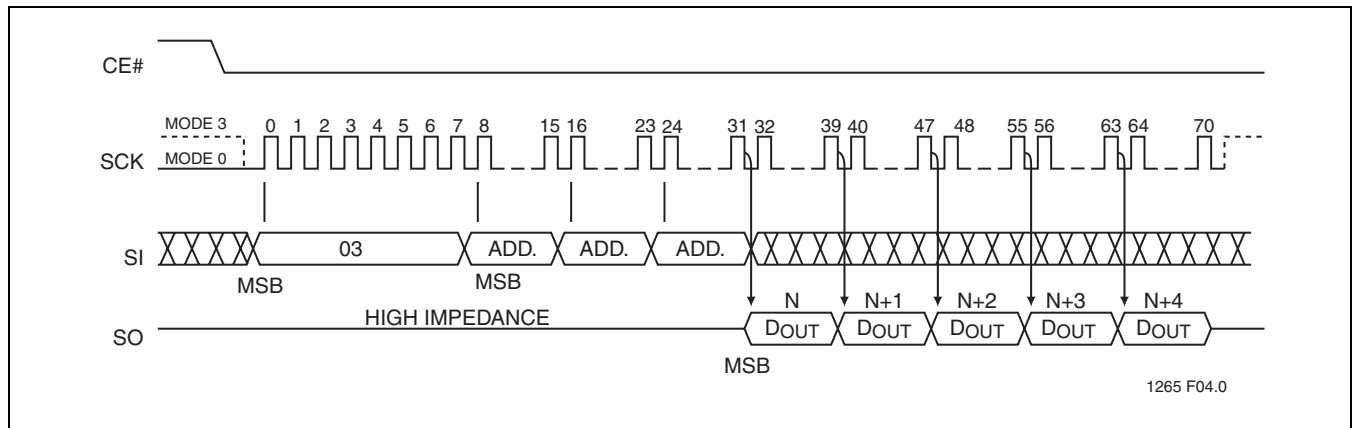

FIGURE 4: READ SEQUENCE



Data Sheet

**High-Speed-Read (33 MHz)**

The High-Speed-Read instruction supporting up to 33 MHz is initiated by executing an 8-bit command, 0BH, followed by address bits [A<sub>23</sub>-A<sub>0</sub>] and a dummy byte. CE# must remain active low for the duration of the High-Speed-Read cycle. See Figure 5 for the High-Speed-Read sequence.

Following a dummy byte (8 clocks input dummy cycle), the High-Speed-Read instruction outputs the data starting from the specified address location. The data output stream is continuous through all addresses until terminated by a low

to high transition on CE#. The internal address pointer will automatically increment until the highest memory address is reached. Once the highest memory address is reached, the address pointer will automatically increment to the beginning (wrap-around) of the address space, i.e. for 4 Mbit density, once the data from address location 07FFFFH has been read, the next output will be from address location 000000H.

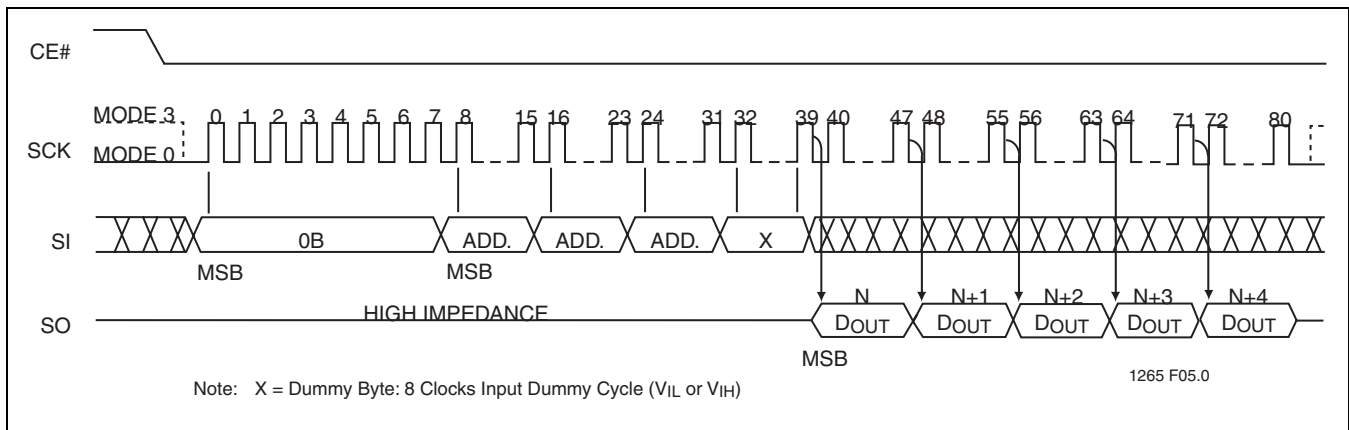

**FIGURE 5: HIGH-SPEED-READ SEQUENCE**



# 1 Mbit SPI Serial Flash D7 T25VF010A

Data Sheet

## Byte-Program

The Byte-Program instruction programs the bits in the selected byte to the desired data. The selected byte must be in the erased state (FFH) when initiating a Program operation. A Byte-Program instruction applied to a protected memory area will be ignored.

Prior to any Write operation, the Write-Enable (WREN) instruction must be executed. CE# must remain active low for the duration of the Byte-Program instruction. The Byte-

Program instruction is initiated by executing an 8-bit command, 02H, followed by address bits [A<sub>23</sub>-A<sub>0</sub>]. Following the address, the data is input in order from MSB (bit 7) to LSB (bit 0). CE# must be driven high before the instruction is executed. The user may poll the Busy bit in the software status register or wait T<sub>BP</sub> for the completion of the internal self-timed Byte-Program operation. See Figure 6 for the Byte-Program sequence.

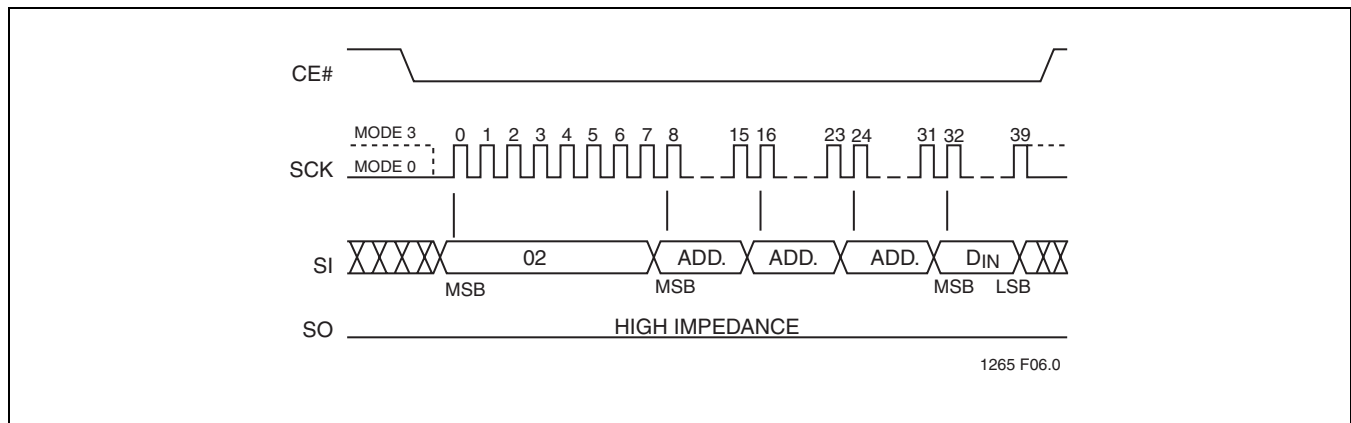

FIGURE 6: BYTE-PROGRAM SEQUENCE



## Data Sheet

### Auto Address Increment (AAI) Program

The AAI program instruction allows multiple bytes of data to be programmed without re-issuing the next sequential address location. This feature decreases total programming time when the entire memory array is to be programmed. An AAI program instruction pointing to a protected memory area will be ignored. The selected address range must be in the erased state (FFH) when initiating an AAI program instruction.

Prior to any write operation, the Write-Enable (WREN) instruction must be executed. The AAI program instruction is initiated by executing an 8-bit command, AFH, followed by address bits [A<sub>23</sub>-A<sub>0</sub>]. Following the addresses, the data is input sequentially from MSB (bit 7) to LSB (bit 0). CE# must be driven high before the AAI program instruction is executed. The user must poll the BUSY bit in the software

status register or wait T<sub>BP</sub> for the completion of each internal self-timed Byte-Program cycle. Once the device completes programming byte, the next sequential address may be programmed, enter the 8-bit command, AFH, followed by the data to be programmed. When the last desired byte had been programmed, execute the Write-Disable (WRDI) instruction, 04H, to terminate AAI. After execution of the WRDI command, the user must poll the Status register to ensure the device completes programming. See Figure 7 for AAI programming sequence.

There is no wrap mode during AAI programming; once the highest unprotected memory address is reached, the device will exit AAI operation and reset the Write-Enable-Latch bit (WEL = 0).

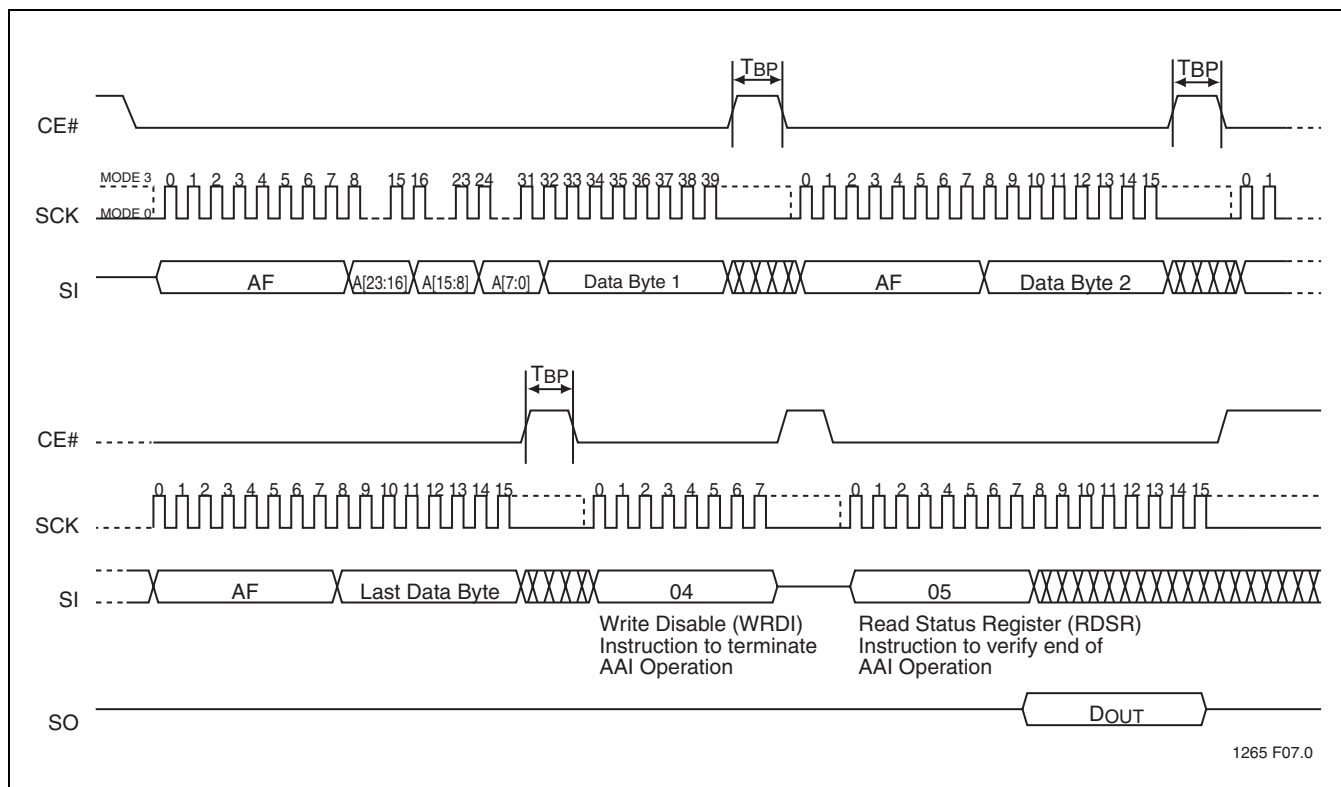

FIGURE 7: AUTO ADDRESS INCREMENT (AAI) PROGRAM SEQUENCE



# 1 Mbit SPI Serial Flash D7 T25VF010A

Data Sheet

## Sector-Erase

The Sector-Erase instruction clears all bits in the selected 4 KByte sector to FFH. A Sector-Erase instruction applied to a protected memory area will be ignored. Prior to any Write operation, the Write-Enable (WREN) instruction must be executed. CE# must remain active low for the duration of the any command sequence. The Sector-Erase instruction is initiated by executing an 8-bit command, 20H, followed by address bits [A<sub>23</sub>-A<sub>0</sub>]. Address bits [A<sub>MS</sub>-A<sub>12</sub>]

(A<sub>MS</sub> = Most Significant address) are used to determine the sector address (SA<sub>X</sub>), remaining address bits can be V<sub>IL</sub> or V<sub>IH</sub>. CE# must be driven high before the instruction is executed. The user may poll the Busy bit in the software status register or wait T<sub>SE</sub> for the completion of the internal self-timed Sector-Erase cycle. See Figure 8 for the Sector-Erase sequence.

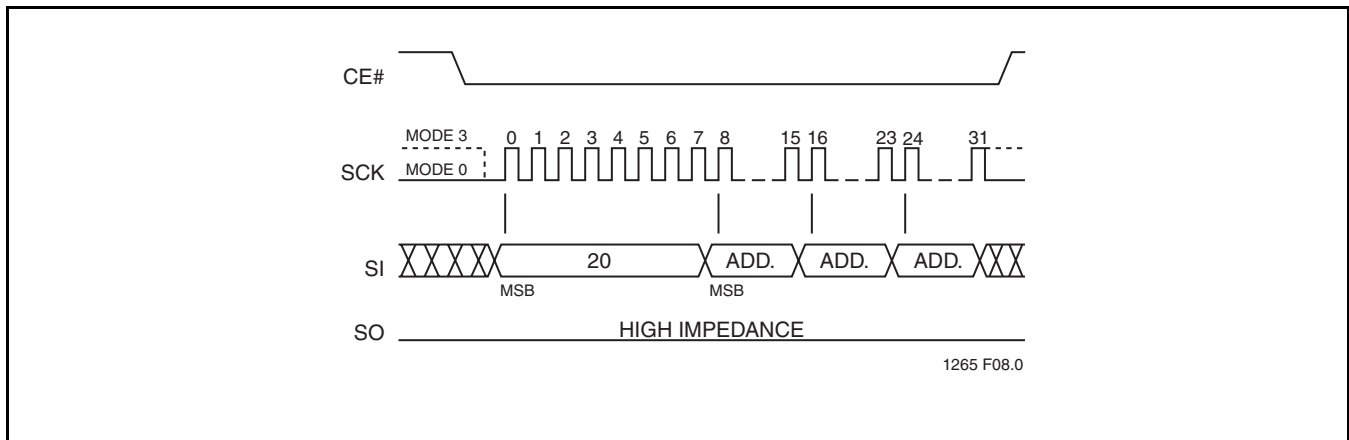

FIGURE 8: SECTOR-ERASE SEQUENCE

## Block-Erase

The Block-Erase instruction clears all bits in the selected 32 KByte block to FFH. A Block-Erase instruction applied to a protected memory area will be ignored. Prior to any Write operation, the Write-Enable (WREN) instruction must be executed. CE# must remain active low for the duration of any command sequence. The Block-Erase instruction is initiated by executing an 8-bit command, 52H or D8H, followed by address bits [A<sub>23</sub>-A<sub>0</sub>]. Address bits [A<sub>MS</sub>-A<sub>15</sub>]

(A<sub>MS</sub> = Most significant address) are used to determine block address (BA<sub>X</sub>), remaining address bits can be V<sub>IL</sub> or V<sub>IH</sub>. CE# must be driven high before the instruction is executed. The user may poll the Busy bit in the software status register or wait T<sub>BE</sub> for the completion of the internal self-timed Block-Erase cycle. See Figure 9 for the Block-Erase sequence.

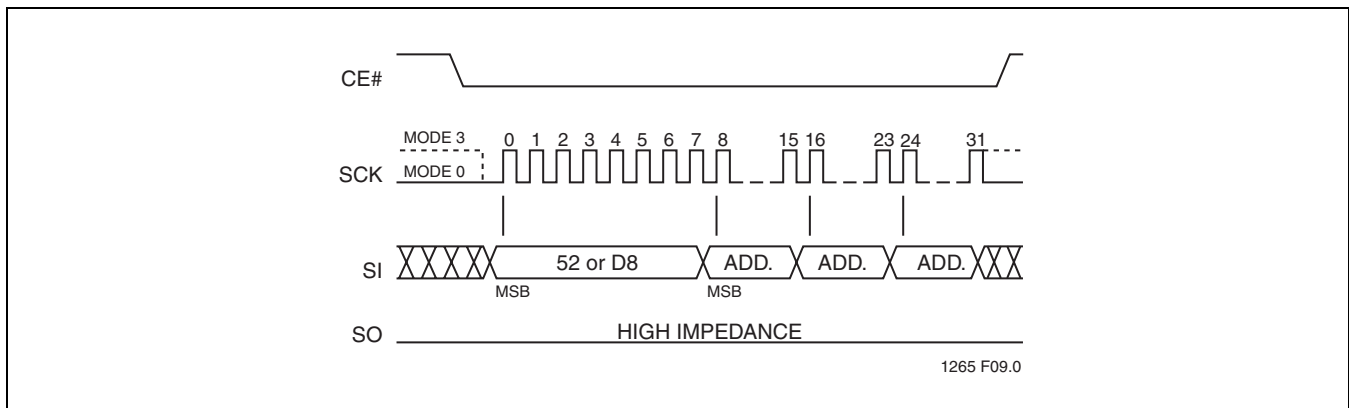

FIGURE 9: BLOCK-ERASE SEQUENCE



Data Sheet

Chip-Erase

The Chip-Erase instruction clears all bits in the device to FFH. A Chip-Erase instruction will be ignored if any of the memory area is protected. Prior to any Write operation, the Write-Enable (WREN) instruction must be executed. CE# must remain active low for the duration of the Chip-Erase instruction sequence. The Chip-Erase instruction is initiated

by executing an 8-bit command, 60H or C7H. CE# must be driven high before the instruction is executed. The user may poll the Busy bit in the software status register or wait  $T_{CE}$  for the completion of the internal self-timed Chip-Erase cycle. See Figure 10 for the Chip-Erase sequence.

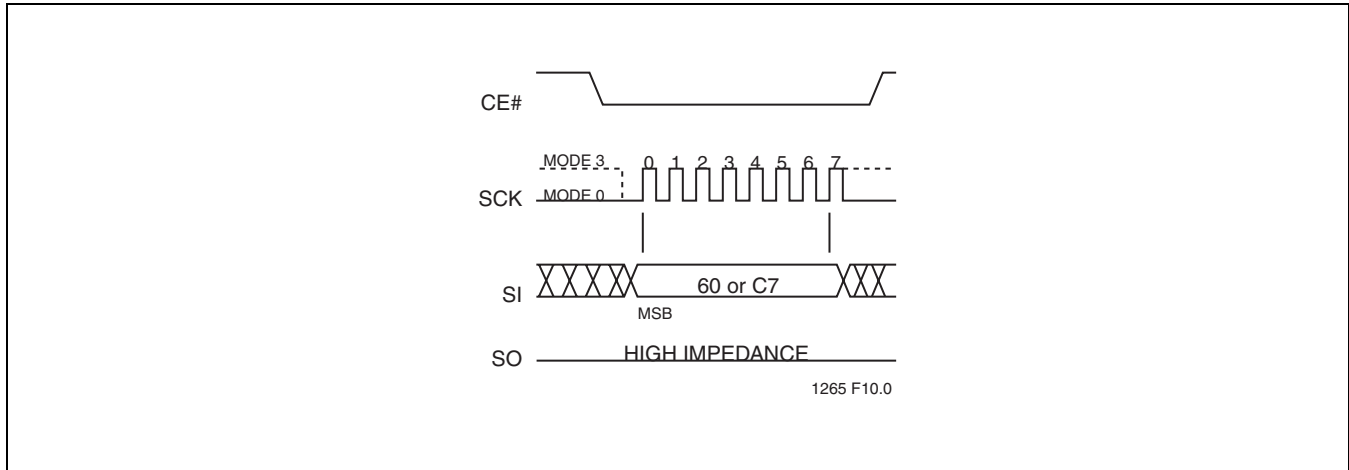

FIGURE 10: CHIP-ERASE SEQUENCE

Read-Status-Register (RDSR)

The Read-Status-Register (RDSR) instruction allows reading of the status register. The status register may be read at any time even during a Write (Program/Erase) operation. When a Write operation is in progress, the Busy bit may be checked before sending any new commands to assure that the new commands are properly received by the device.

CE# must be driven low before the RDSR instruction is entered and remain low until the status data is read. Read-Status-Register is continuous with ongoing clock cycles until it is terminated by a low to high transition of the CE#. See Figure 11 for the RDSR instruction sequence.

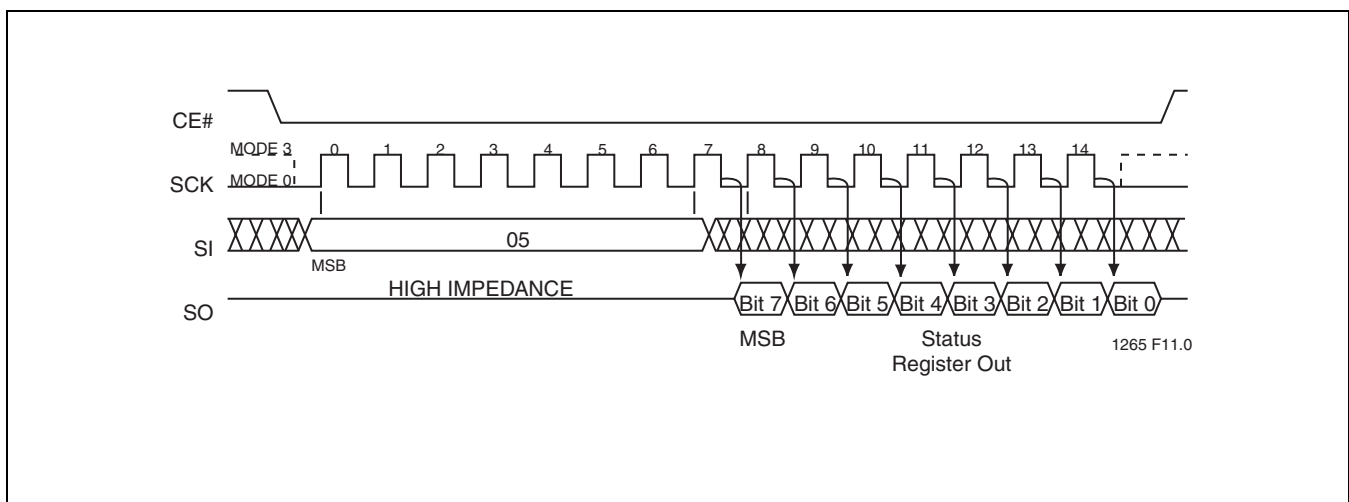

FIGURE 11: READ-STATUS-REGISTER (RDSR) SEQUENCE



# 1 Mbit SPI Serial Flash D7 T25VF010A

## Write-Enable (WREN)

The Write-Enable (WREN) instruction sets the Write-Enable-Latch bit to 1 allowing Write operations to occur. The WREN instruction must be executed prior to any Write (Program/Erase) operation. CE# must be driven high before the WREN instruction is executed.

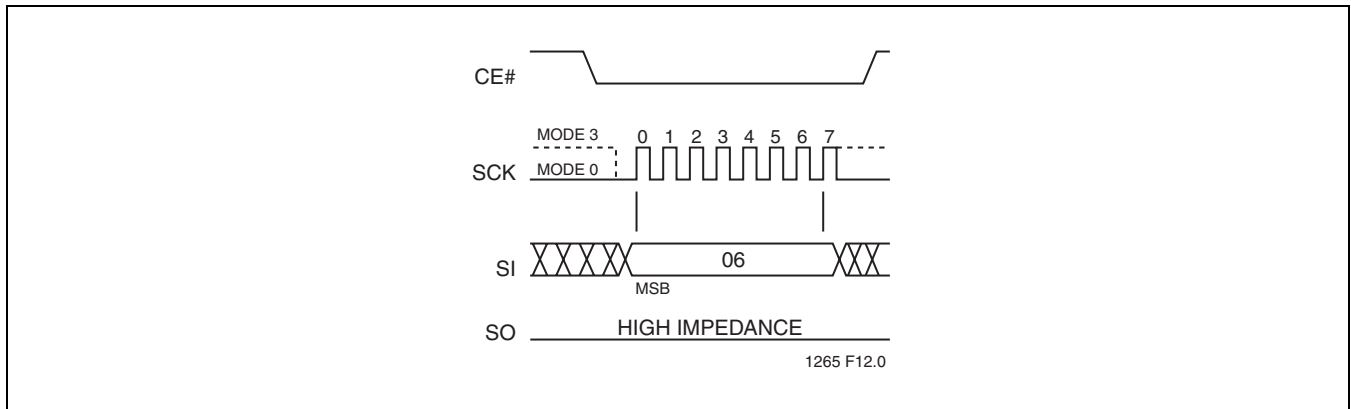

FIGURE 12: WRITE ENABLE (WREN) SEQUENCE

## Write-Disable (WRDI)

The Write-Disable (WRDI) instruction resets the Write-Enable-Latch bit and AAI bit to 0 disabling any new Write operations from occurring. CE# must be driven high before the WRDI instruction is executed.

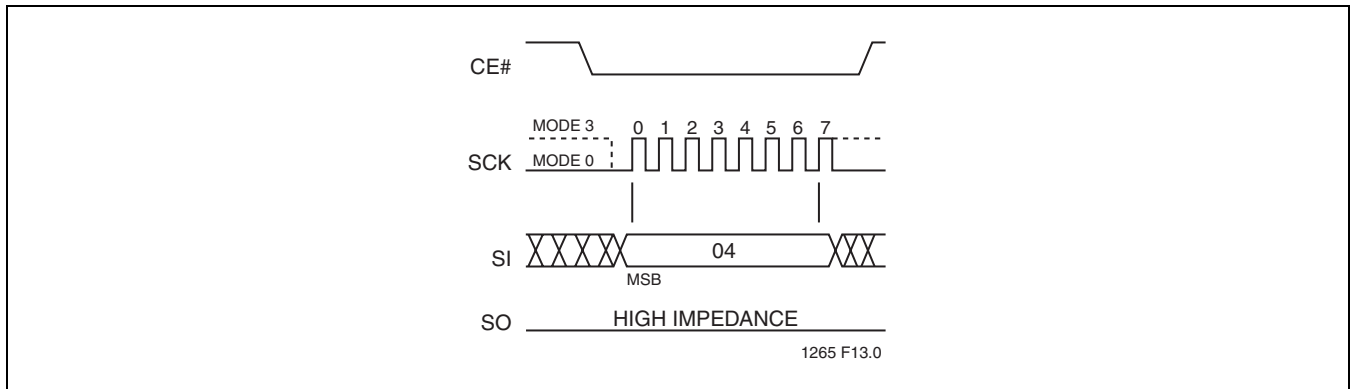

FIGURE 13: WRITE DISABLE (WRDI) SEQUENCE

## Enable-Write-Status-Register (EWSR)

The Enable-Write-Status-Register (EWSR) instruction arms the Write-Status-Register (WRSR) instruction and opens the status register for alteration. The Enable-Write-Status-Register instruction does not have any effect and will be wasted, if it is not followed immediately by the Write-

Status-Register (WRSR) instruction. CE# must be driven low before the EWSR instruction is entered and must be driven high before the EWSR instruction is executed.



Data Sheet

**Write-Status-Register (WRSR)**

The Write-Status-Register instruction works in conjunction with the Enable-Write-Status-Register (EWSR) instruction to write new values to the BP1, BP0, and BPL bits of the status register. The Write-Status-Register instruction must be executed immediately after the execution of the Enable-Write-Status-Register instruction (very next instruction bus cycle). This two-step instruction sequence of the EWSR instruction followed by the WRSR instruction works like SDP (software data protection) command structure which prevents any accidental alteration of the status register values. The Write-Status-Register instruction will be ignored when WP# is low and BPL bit is set to "1". When the WP# is low, the BPL bit can only be set from "0" to "1" to lock-down the status register, but cannot be reset from "1" to "0".

When WP# is high, the lock-down function of the BPL bit is disabled and the BPL, BP0, and BP1 bits in the status register can all be changed. As long as BPL bit is set to 0 or WP# pin is driven high ( $V_{IH}$ ) prior to the low-to-high transition of the CE# pin at the end of the WRSR instruction, the BP0, BP1, and BPL bit in the status register can all be altered by the WRSR instruction. In this case, a single WRSR instruction can set the BPL bit to "1" to lock down the status register as well as altering the BP0 and BP1 bit at the same time. See Table 3 for a summary description of WP# and BPL functions. CE# must be driven low before the command sequence of the WRSR instruction is entered and driven high before the WRSR instruction is executed. See Figure 14 for EWSR and WRSR instruction sequences.

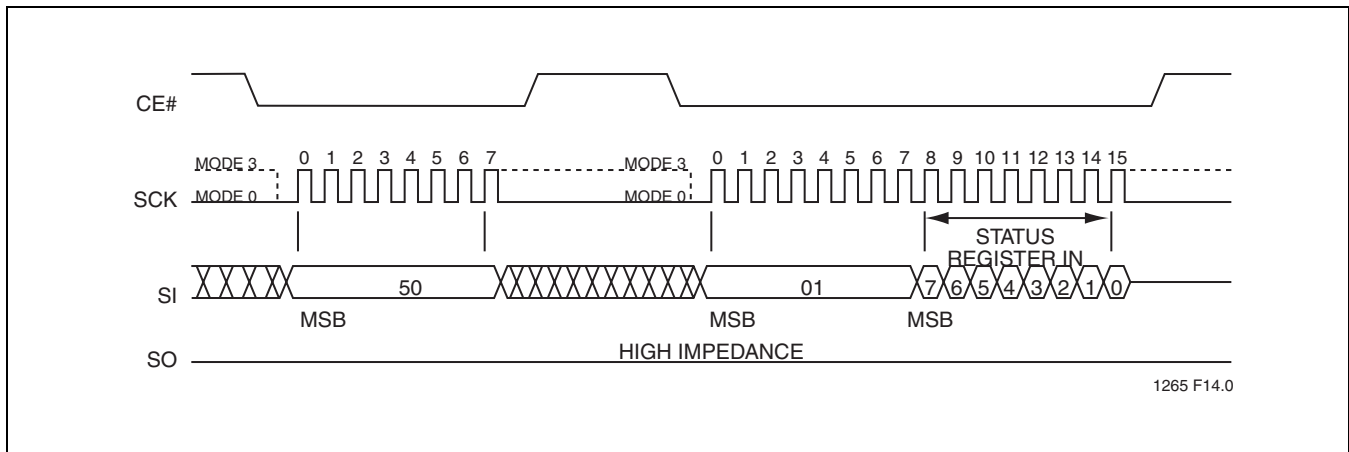

**FIGURE 14: ENABLE-WRITE-STATUS-REGISTER (EWSR) AND WRITE-STATUS-REGISTER (WRSR) SEQUENCE**





# 1 Mbit SPI Serial Flash D7 T25VF010A

Data Sheet

## Read-ID

The Read-ID instruction identifies the device as PCT25VF010A and manufacturer as PCT. The device information can be read from executing an 8-bit command, 90H or ABH, followed by address bits [A<sub>23</sub>-A<sub>0</sub>]. Following the Read-ID instruction, the manufacturer's ID is located in

address 00000H and the device ID is located in address 00001H. Once the device is in Read-ID mode, the manufacturer's and device ID output data toggles between address 00000H and 00001H until terminated by a low to high transition on CE#.

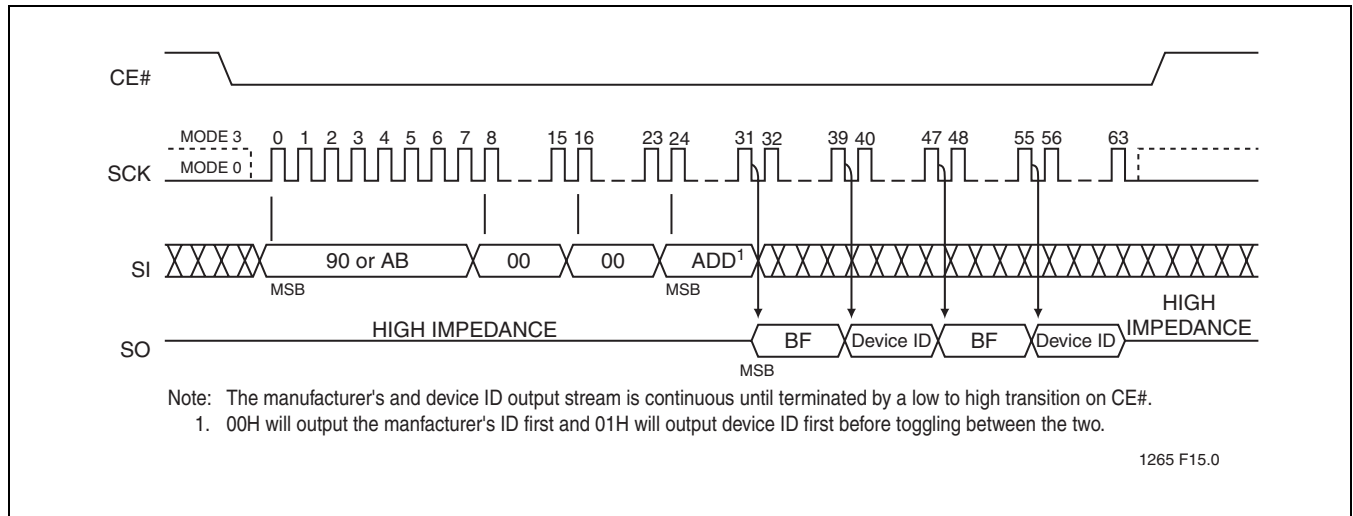

FIGURE 15: READ-ID SEQUENCE



**ELECTRICAL SPECIFICATIONS**

**Absolute Maximum Stress Ratings** (Applied conditions greater than those listed under “Absolute Maximum Stress Ratings” may cause permanent damage to the device. This is a stress rating only and functional operation of the device at these conditions or conditions greater than those defined in the operational sections of this data sheet is not implied. Exposure to absolute maximum stress rating conditions may affect device reliability.)

Temperature Under Bias	-55°C to +125°C
Storage Temperature	-65°C to +150°C
D. C. Voltage on Any Pin to Ground Potential	-0.5V to V <sub>DD</sub> +0.5V
Transient Voltage (<20 ns) on Any Pin to Ground Potential	-2.0V to V <sub>DD</sub> +2.0V
Package Power Dissipation Capability (T <sub>A</sub> = 25°C)	1.0W
Surface Mount Solder Reflow Temperature	260°C for 10 seconds
Output Short Circuit Current <sup>1</sup>	50 mA

1. Output shorted for no more than one second. No more than one output shorted at a time.

**OPERATING RANGE**

Range	Ambient Temp	V <sub>DD</sub>
Commercial	0°C to +70°C	2.7-3.6V
Industrial	-40°C to +85°C	2.7-3.6V
Extended	-20°C to +85°C	2.7-3.6V

**AC CONDITIONS OF TEST**

Input Rise/Fall Time	5 ns
Output Load	C <sub>L</sub> = 30 pF
See Figures 20 and 21	

**TABLE 7: DC OPERATING CHARACTERISTICS V<sub>DD</sub> = 2.7-3.6V**

Symbol	Parameter	Limits			Test Conditions
		Min	Max	Units	
I <sub>DDR</sub>	Read Current		10	mA	CE#=0.1 V <sub>DD</sub> /0.9 V <sub>DD</sub> @20 MHz, SO=open
I <sub>DDW</sub>	Program and Erase Current		30	mA	CE#=V <sub>DD</sub>
I <sub>SB</sub>	Standby Current		15	µA	CE#=V <sub>DD</sub> , V <sub>IN</sub> =V <sub>DD</sub> or V <sub>SS</sub>
I <sub>LI</sub>	Input Leakage Current		1	µA	V <sub>IN</sub> =GND to V <sub>DD</sub> , V <sub>DD</sub> =V <sub>DD</sub> Max
I <sub>LO</sub>	Output Leakage Current		1	µA	V <sub>OUT</sub> =GND to V <sub>DD</sub> , V <sub>DD</sub> =V <sub>DD</sub> Max
V <sub>IL</sub>	Input Low Voltage		0.8	V	V <sub>DD</sub> =V <sub>DD</sub> Min
V <sub>IH</sub>	Input High Voltage	0.7 V <sub>DD</sub>		V	V <sub>DD</sub> =V <sub>DD</sub> Max
V <sub>OL</sub>	Output Low Voltage		0.2	V	I <sub>OL</sub> =100 µA, V <sub>DD</sub> =V <sub>DD</sub> Min
V <sub>OH</sub>	Output High Voltage	V <sub>DD</sub> -0.2		V	I <sub>OH</sub> =-100 µA, V <sub>DD</sub> =V <sub>DD</sub> Min

T7.0 1265

**TABLE 8: RECOMMENDED SYSTEM POWER-UP TIMINGS**

Symbol	Parameter	Minimum	Units
T <sub>PU-READ</sub> <sup>1</sup>	V <sub>DD</sub> Min to Read Operation	10	µs
T <sub>PU-WRITE</sub> <sup>1</sup>	V <sub>DD</sub> Min to Write Operation	10	µs

T8.0 1265

1. This parameter is measured only for initial qualification and after a design or process change that could affect this parameter.



# 1 Mbit SPI Serial Flash

## D7 T25VF010A

Data Sheet

**TABLE 9: CAPACITANCE** ( $T_A = 25^\circ\text{C}$ ,  $f = 1\text{ Mhz}$ , other pins open)

Parameter	Description	Test Condition	Maximum
$C_{OUT}^1$	Output Pin Capacitance	$V_{OUT} = 0V$	12 pF
$C_{IN}^1$	Input Capacitance	$V_{IN} = 0V$	6 pF

T9.0 1265

1. This parameter is measured only for initial qualification and after a design or process change that could affect this parameter.

**TABLE 10: RELIABILITY CHARACTERISTICS**

Symbol	Parameter	Minimum Specification	Units	Test Method
$N_{END}^1$	Endurance	10,000	Cycles	JEDEC Standard A117
$T_{DR}^1$	Data Retention	100	Years	JEDEC Standard A103
$I_{LTH}^1$	Latch Up	$100 + I_{DD}$	mA	JEDEC Standard 78

T10.0 1265

1. This parameter is measured only for initial qualification and after a design or process change that could affect this parameter.

**TABLE 11: AC OPERATING CHARACTERISTICS**  $V_{DD} = 2.7\text{-}3.6V$

Symbol	Parameter	Limits				Units
		20 MHz		33 MHz		
		Min	Max	Min	Max	
$F_{CLK}$	Serial Clock Frequency		20		33	MHz
$T_{SCKH}$	Serial Clock High Time	20		13		ns
$T_{SCKL}$	Serial Clock Low Time	20		13		ns
$T_{SCKR}^1$	Serial Clock Rise Time (slew rate)	0.1		0.1		V/ns
$T_{SCKF}^1$	Serial Clock Fall Time (slew rate)	0.1		0.1		V/ns
$T_{CES}^2$	CE# Active Setup Time	20		12		ns
$T_{CEH}^2$	CE# Active Hold Time	20		12		ns
$T_{CHS}^2$	CE# Not Active Setup Time	10		10		ns
$T_{CHH}^2$	CE# Not Active Hold Time	10		10		ns
$T_{CPH}$	CE# High Time	100		100		ns
$T_{CHZ}$	CE# High to High-Z Output		20		14	ns
$T_{CLZ}$	SCK Low to Low-Z Output	0		0		ns
$T_{DS}$	Data In Setup Time	5		3		ns
$T_{DH}$	Data In Hold Time	5		3		ns
$T_{HLS}$	HOLD# Low Setup Time	10		10		ns
$T_{HHS}$	HOLD# High Setup Time	10		10		ns
$T_{HLH}$	HOLD# Low Hold Time	15		10		ns
$T_{HHH}$	HOLD# High Hold Time	10		10		ns
$T_{HZ}$	HOLD# Low to High-Z Output		20		14	ns
$T_{LZ}$	HOLD# High to Low-Z Output		20		14	ns
$T_{OH}$	Output Hold from SCK Change	0		0		ns
$T_V$	Output Valid from SCK		20		12	ns
$T_{SE}$	Sector-Erase		25		25	ms
$T_{BE}$	Block-Erase		25		25	ms
$T_{SCE}$	Chip-Erase		100		100	ms
$T_{BP}$	Byte-Program		20		20	$\mu\text{s}$

T11.0 1265

1. Maximum Serial Clock Rise and Fall times may be limited by  $T_{SCKH}$  and  $T_{SCKL}$  requirements.  
 2. Relative to SCK.

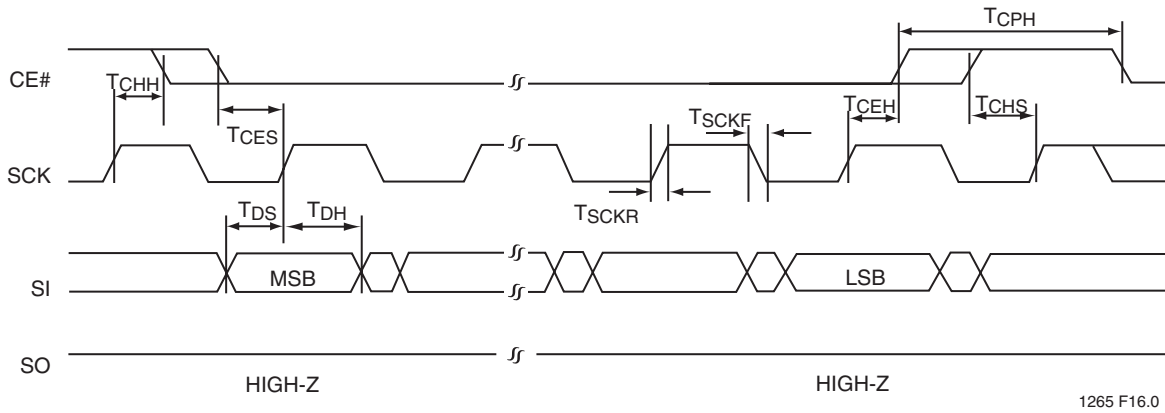

1265 F16.0

FIGURE 16: SERIAL INPUT TIMING DIAGRAM

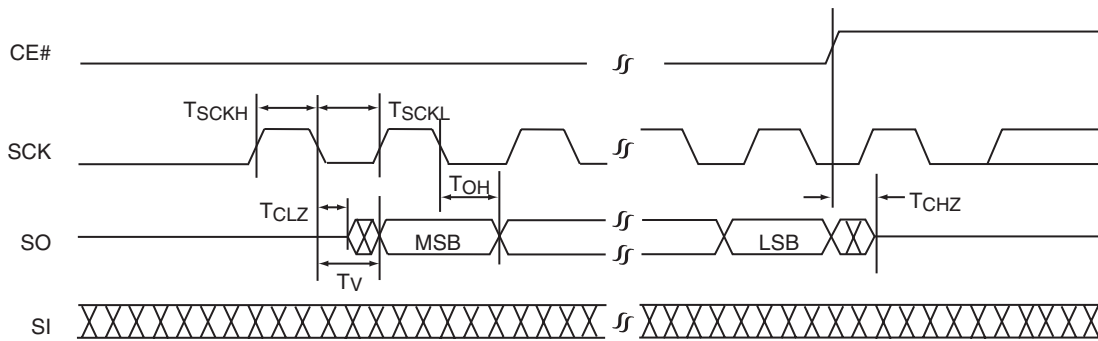

1265 F17.0

FIGURE 17: SERIAL OUTPUT TIMING DIAGRAM

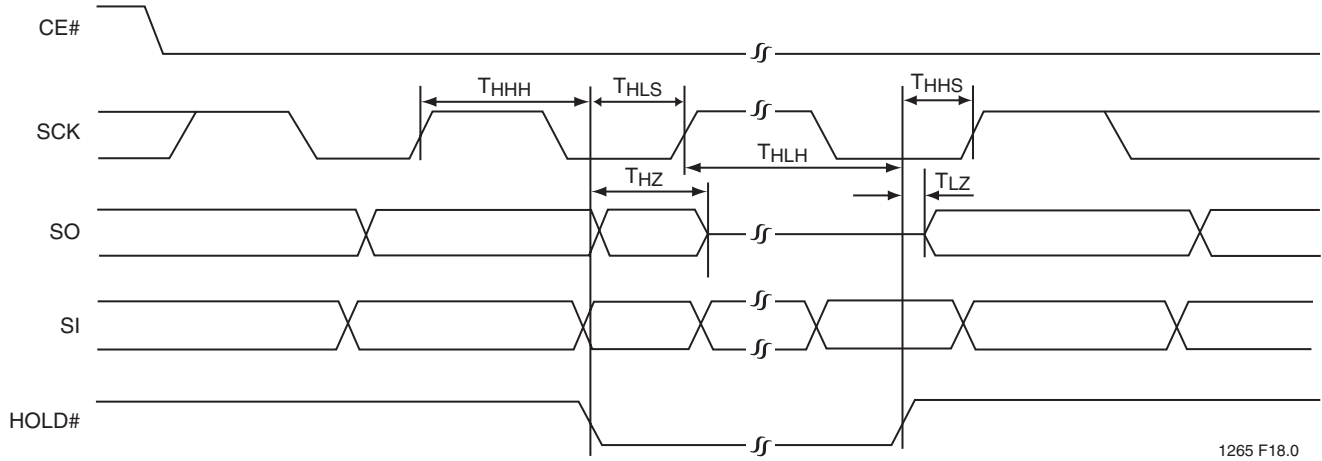

FIGURE 18: HOLD TIMING DIAGRAM

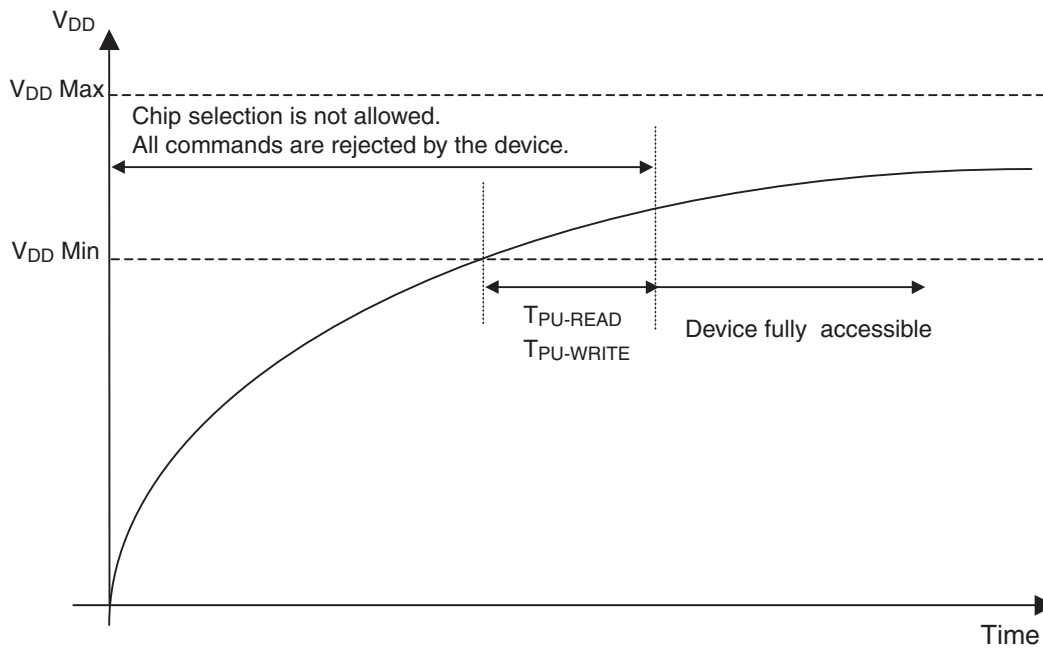
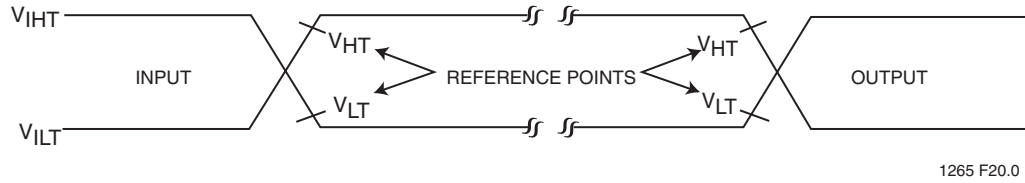

FIGURE 19: POWER-UP TIMING DIAGRAM



AC test inputs are driven at  $V_{IHT}$  ( $0.9V_{DD}$ ) for a logic "1" and  $V_{ILT}$  ( $0.1V_{DD}$ ) for a logic "0". Measurement reference points for inputs and outputs are  $V_{HT}$  ( $0.7V_{DD}$ ) and  $V_{LT}$  ( $0.3V_{DD}$ ). Input rise and fall times (10%  $\leftrightarrow$  90%) are  $<5$  ns.

**Note:**  $V_{HT}$  -  $V_{HIGH}$  Test  
 $V_{LT}$  -  $V_{LOW}$  Test  
 $V_{IHT}$  -  $V_{INPUT HIGH}$  Test  
 $V_{ILT}$  -  $V_{INPUT LOW}$  Test

FIGURE 20: AC INPUT/OUTPUT REFERENCE WAVEFORMS

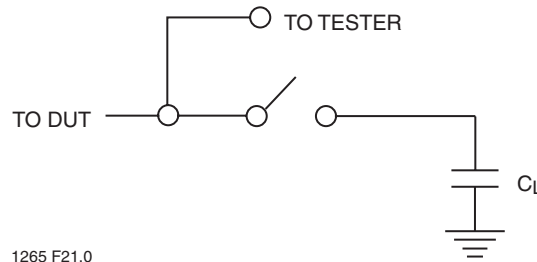

FIGURE 21: A TEST LOAD EXAMPLE



# 1 Mbit SPI Serial Flash

## D7 T25VF010A

Data Sheet

### PRODUCT ORDERING INFORMATION

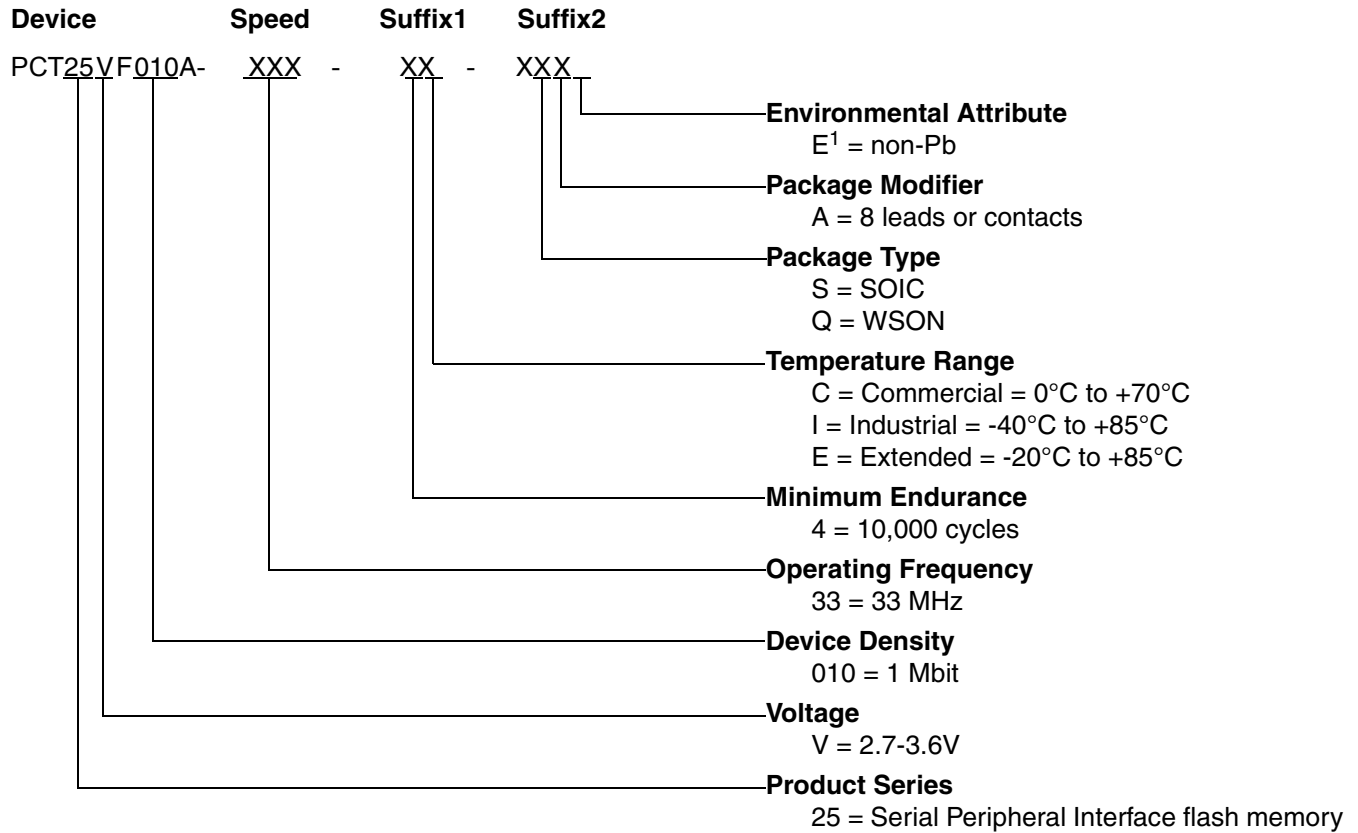

1. Environmental suffix "E" denotes non-Pb solder.  
PCT non-Pb solder devices are "RoHS Compliant".

#### Valid combinations for D7 T25VF010A

PCT25VF010A-33-4C-SAE	PCT25VF010A-33-4C-QAE
PCT25VF010A-33-4I-SAE	PCT25VF010A-33-4I-QAE
PCT25VF010A-33-4E-SAE	PCT25VF010A-33-4E-QAE

**Note:** Valid combinations are those products in mass production or will be in mass production. Consult your PCT sales representative to confirm availability of valid combinations and to determine availability of new combinations.



Data Sheet

### PACKAGING DIAGRAMS

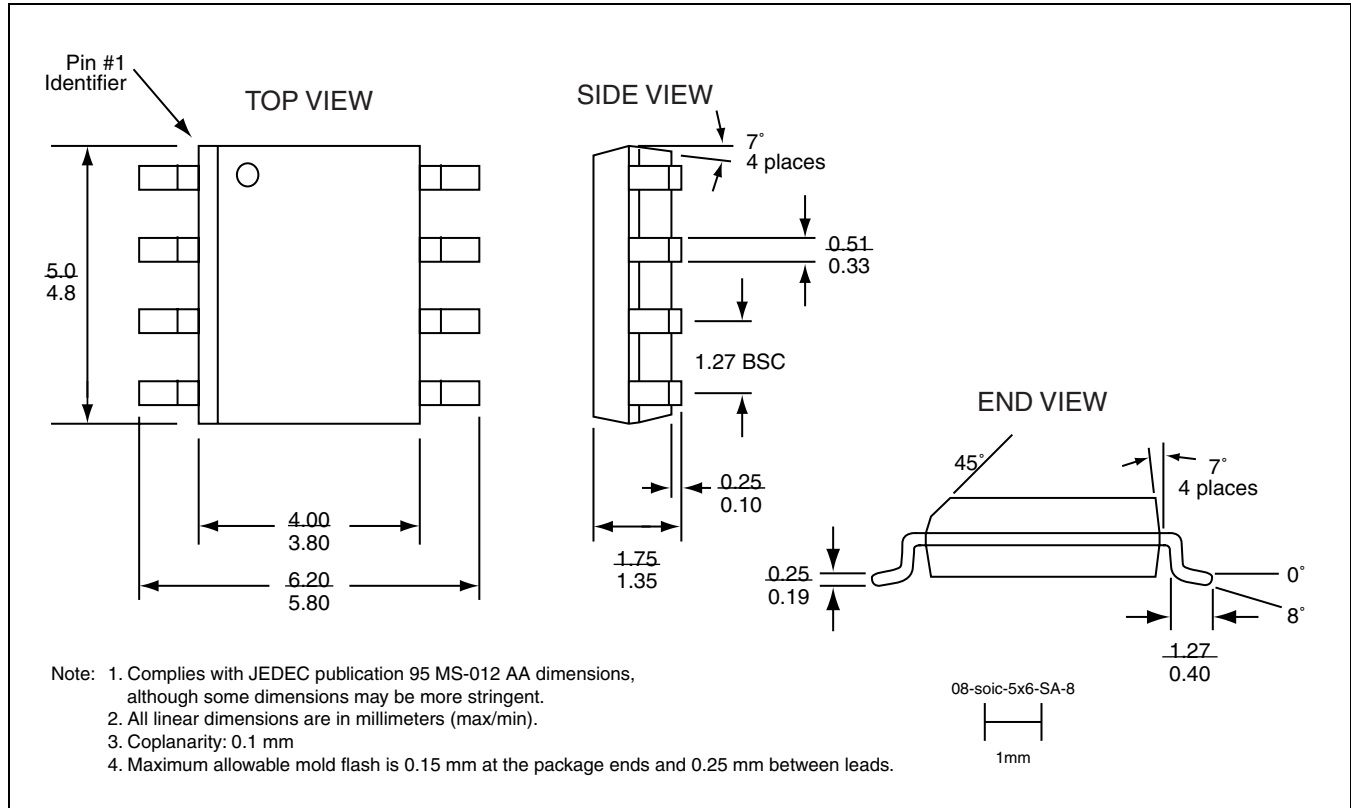

**8-LEAD SMALL OUTLINE INTEGRATED CIRCUIT (SOIC) 150 MIL BODY WIDTH (4.9MM X 6MM)  
PCT PACKAGE CODE: SA**



